

# compact 3

automatic spraying machine

finishing systems



REV. N. 00 - 04-2018 - MIC-STUDIO - KOMMA - DIGITALPRINT



19303111

ELMAG SPA  
Via Raffaello Sanzio, 11- 20852 Villasanta (MB) - Italy  
tel. +39 039 23611 - fax. +39 039 328242  
info@superfici.com  
www.scmwood.com  
www.superfici.com



# compact 3

automatic spraying machine



## OUR TECHNOLOGY BEHIND YOUR IDEAS

**Compact 3.** Quality automated spraying at your fingertips.



# compact 3

automatic spraying machine



- **HIGH FINISHING QUALITY**

Thanks to the advanced technical specifications and high quality construction. The Compact Sprayer shows a special attention to the achievement of high quality standards in the final product, due to, for example, the lacquer application in two steps achieved by the double arm reciprocator and to the pressurized cabin with double stage air inlet filtration and full size filtering roof.

- **EASY USE AND PRODUCTION QUALITY CONSISTENCY**

Features the user-friendly control software "Optispray". This intuitive software controls the spraying parameters, the storage of working recipes, and their simple recall; thus achieving high quality results.

- **LIMITED INVESTMENT**

Compact 3 is greatest value for the money. The space saving and inexpensive COMPACT 3 guarantees all the advantages of automated lines and makes them affordable to small and medium size companies. If combined with flat dryers for the fast flash off and drying of solvent based, water-borne or UV lacquers, COMPACT 3 is the basis of these automated lines, which fulfil the customers' finishing needs.

# compact 3

compact and more



## DOUBLE SPRAYING ARM

Compact 3 is always supplied with a double spraying arm, so as to have lacquer application in two stages for the best finish quality.



## DRY FILTRATION OR FILTER ON DEMAND

The machine offers as an option the filtration system FILTER ON DEMAND, i.e., the dry filter which automatically changes over at the operator request or after a certain amount of sprayed square meters of substrate.



## VERSATILITY IN THE SELECTION OF DIFFERENT CONVEYING SYSTEMS

The Compact machine range offers the possibility to select the most suitable version to perfectly suit production needs. The machine can be supplied with lacquer reclaiming and conveyor belt cleaning system or, as an alternative, with paper protective system. We also offer the new hybrid conveyor, which makes it possible to work either with paper protection or with lacquer reclaiming as needed.



# compact 3 R

compact and reclaiming

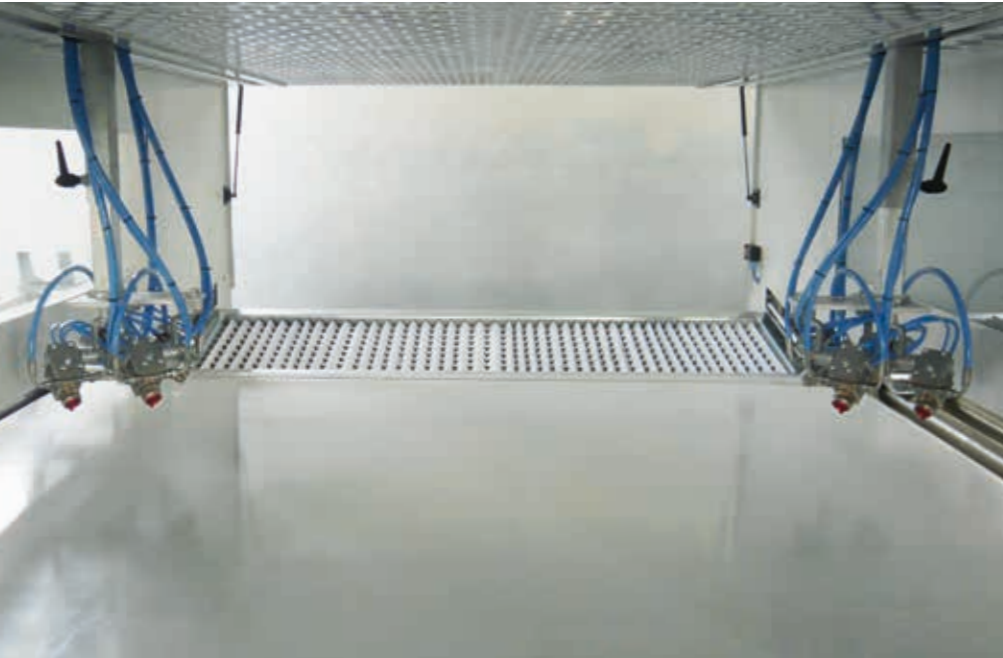

## COMPACT 3 R

Machine executed with a self-cleaning conveyor belt, which continuously and automatically cleans the spraying belt, and, if possible for the lacquer type in use, the lacquer reclaiming and reuse.

# compact 3 P

compact and paper



Lacquer reclaiming unit **SCRAPE ON WET**. The system's principle is to apply on the belt the same lacquer material which is being sprayed. The fresh applied lacquer re-activates the dry lacquer particles on the belt and it can be then easily removed by a scraper.

The reclaiming unit is installed on a removable trolley to ease the cleaning operations.



## COMPACT 3 P

Machine supplied with a paper protective system, it is the ideal solution to operate with small batches with frequent lacquer or colour changes. The paper is automatically unrolled and rewound at the work-piece through-feed and it protects the conveyor placed below and immediately absorbs the overspray. The change over from a job to another is immediate and it does not need cleaning operations, except those related to the spraying circuits.

# compact 3 Hy

compact and hybrid



# compact 3

Pressurized cabin

Inner cabin with extremely neat lines and full size filtering roof, to optimally handle the overspray as a guarantee of application quality.

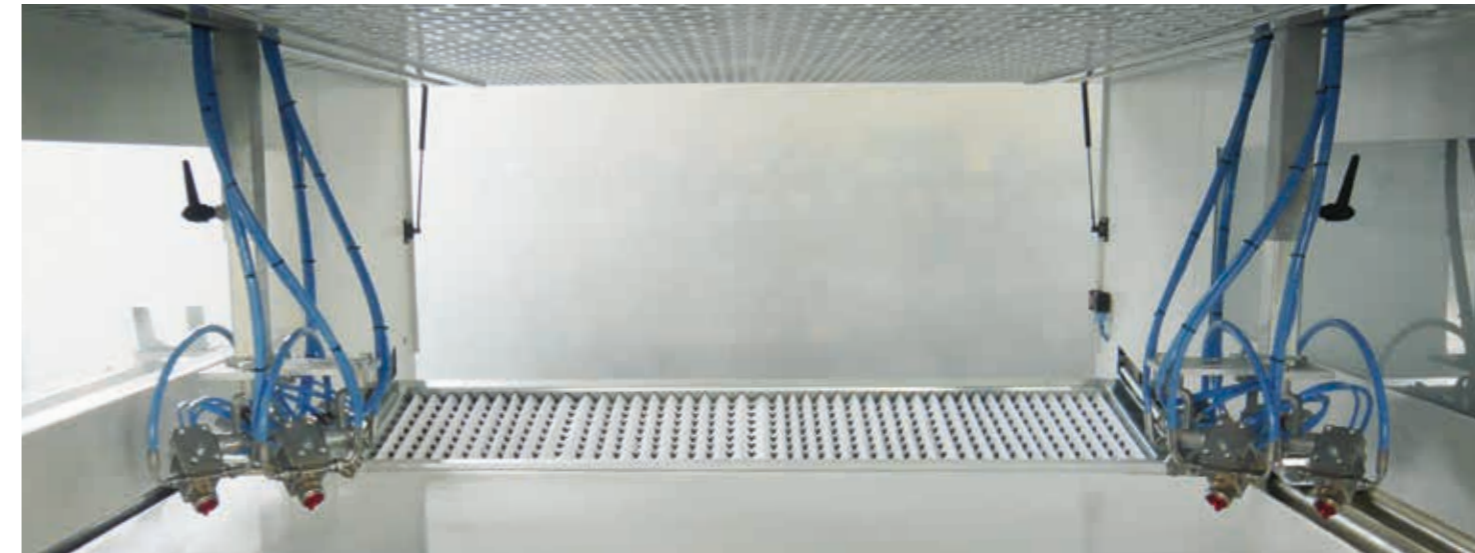

## COMPACT 3 Hy

Machine executed with a hybrid conveying system, which makes it possible to work either with the lacquer reclaiming / cleaning unit or with the protective paper.

This hybrid machine is extremely versatile: it is in fact possible to select the paper protection system in case of small batches, while it is possible to activate the lacquer reclaiming device for larger production runs.



Easily removable roof filtering elements, with all mechanical parts placed over the filtering roof to avoid the risk of contamination.



The full size doors access the cabin from both sides to ease cleaning and maintenance operations.

# compact 3

Spraying arm and circuits

options

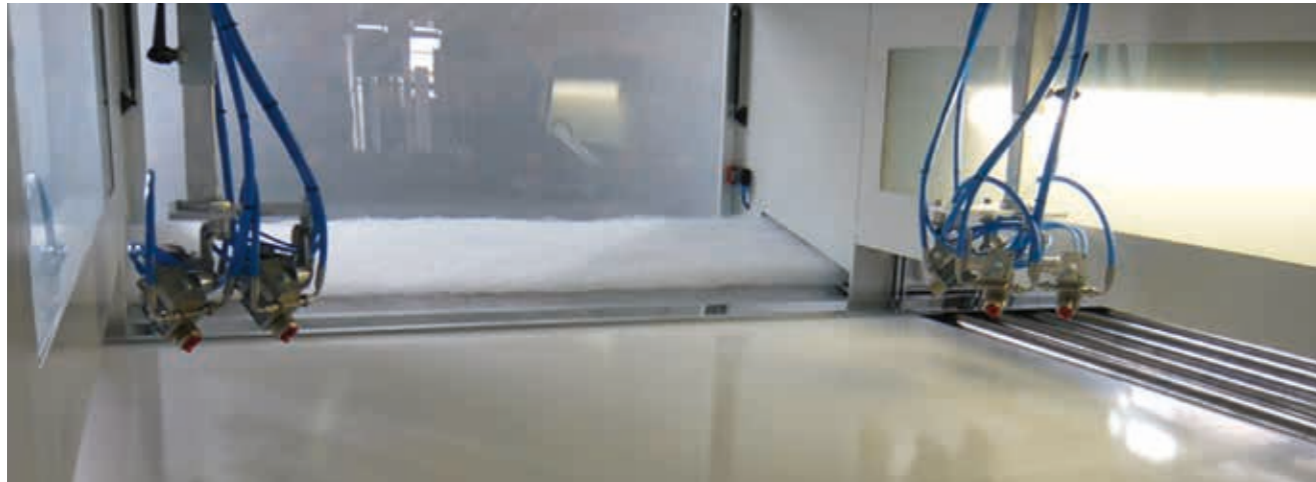

Double reciprocating arm complete with 2 lacquer circuits (a third one can be added as an option). In the standard execution, each arm carries 4 guns. On request it is also possible to have gun holders to carry 6 guns per each arm.

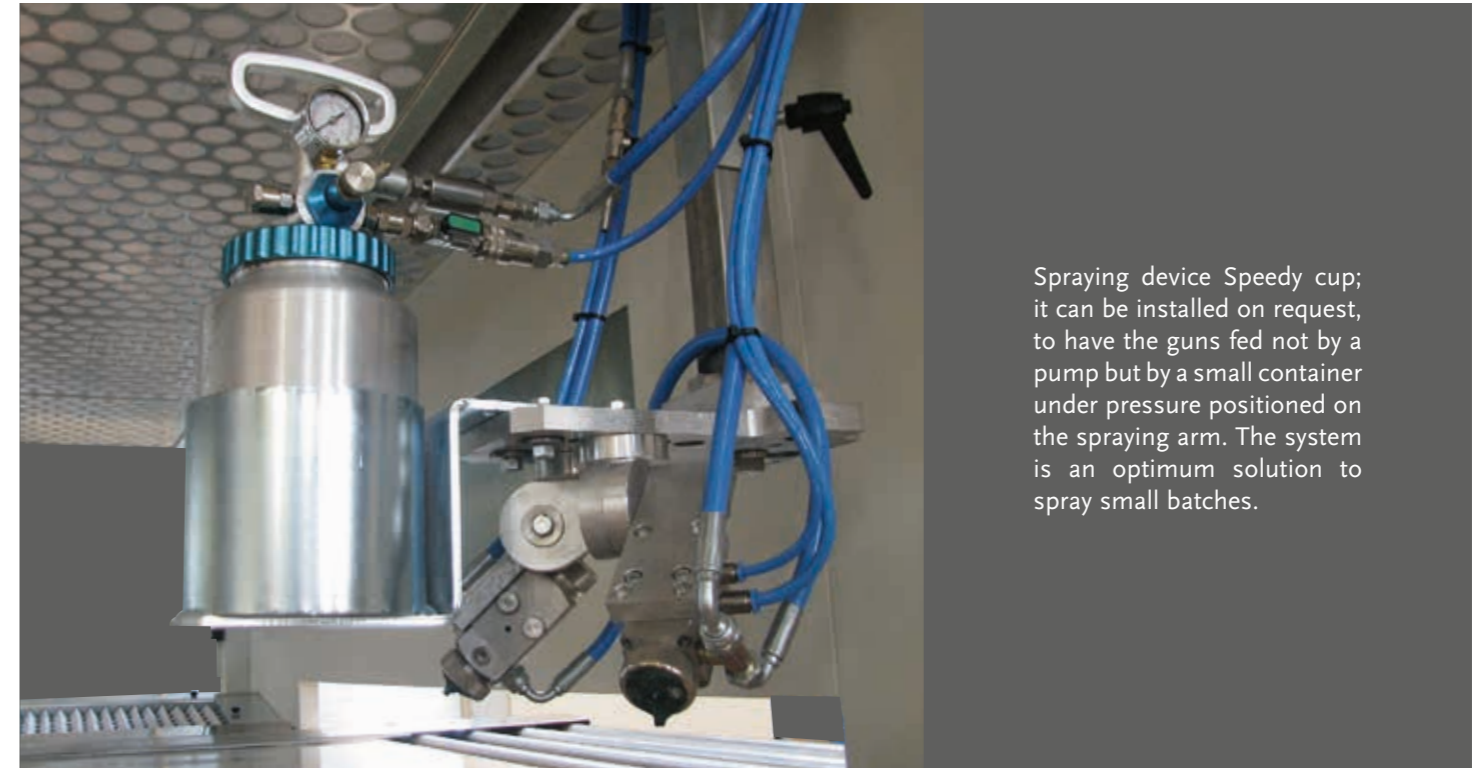

Spraying device Speedy cup; it can be installed on request, to have the guns fed not by a pump but by a small container under pressure positioned on the spraying arm. The system is an optimum solution to spray small batches.



Manometers to control the gun atomizing are placed outside the cabin in a convenient position to have a correct view of the arms.

The machine control can be supplied complete with automatic colour change software integrated in the main control software, to initiate external colour change devices, which achieve the automatic change over from one colour or product to the next one in minimum time.

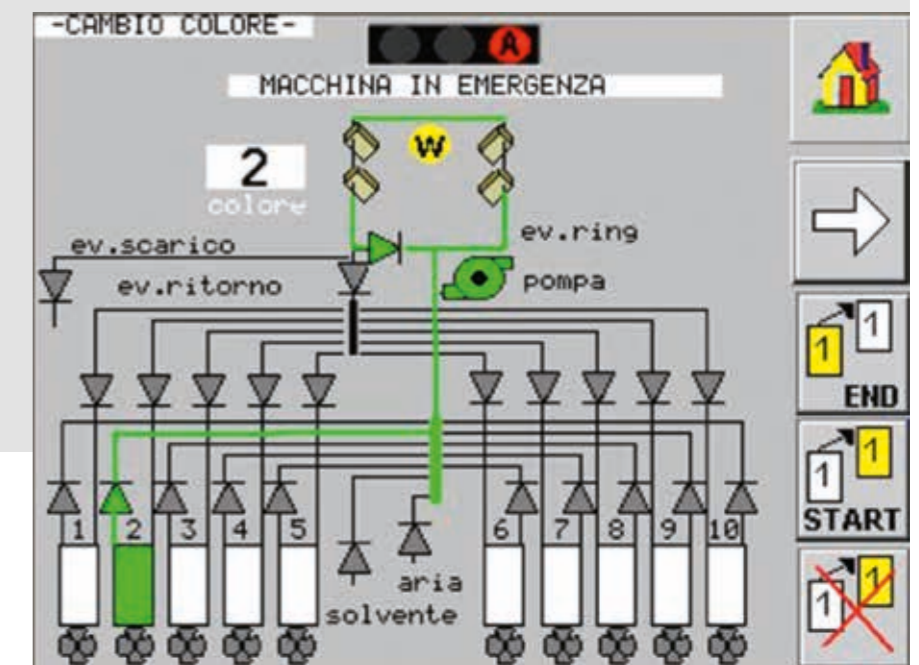

# compact 3

Air filtration

options

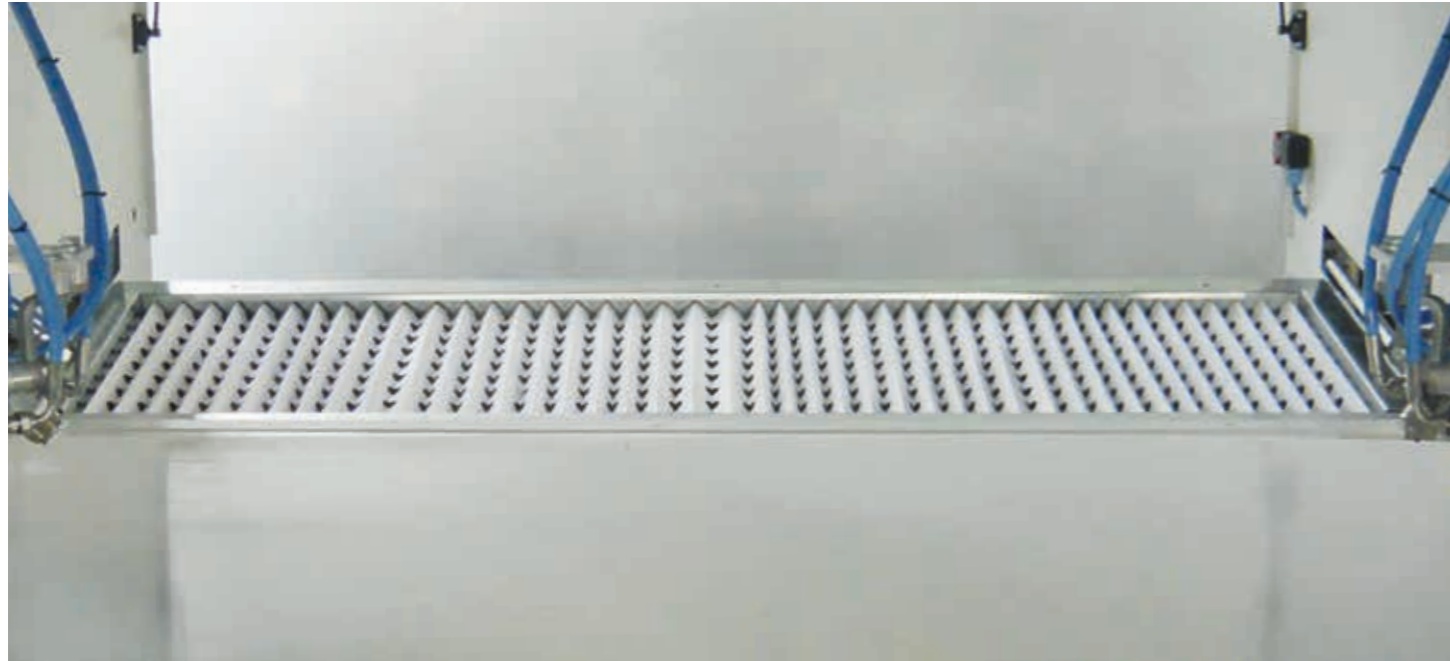

The machine features dry filtration with double filtering layers (cardboard + synthetic fiber). The filtering boxes positioned on the two sides of the spraying conveyor are completely removable from the sides to ease cleaning operations.



As an alternative, the machine can be supplied with the filtering system FILTER ON DEMAND. A synthetic filtering material is automatically unrolled over the side filtering areas. The filter change over is ordered by the operator or it can be set so that it is automatically done once a certain number of square meters are produced. The system achieves:

- Ventilation conditions inside the cabin are always within pre-determined levels, thus guaranteeing the quality of the finished product.
- The filter change-over is without any line stop and with no need of entering the cabin.



# compact 3

Work-piece scanning and control



Work-piece scanning at the machine infeed to recognize the size and position of the pieces, so to automatically control the opening and closing of the guns according to the incoming work-pieces and to the over-spray patterns set up in the working recipe.



Electronic control via PLC and touch panel; user-friendly software controls the spraying parameters, stores the working recipes, eases diagnostics and programs the ordinary maintenance.  
As an alternative, the machine can be supplied with a PC as the operator interface.

## Technical details

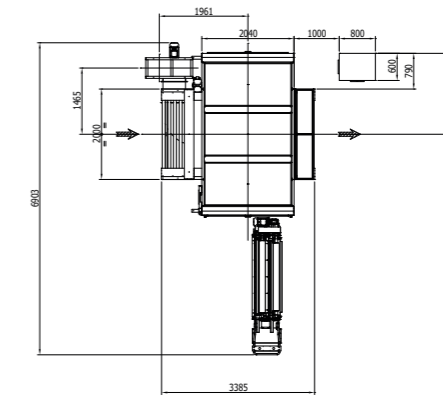
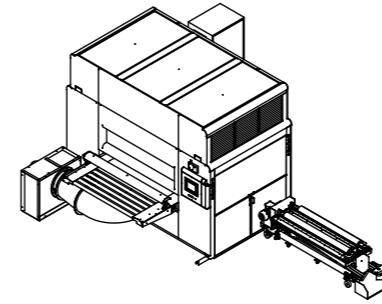

COMPACT 3 R

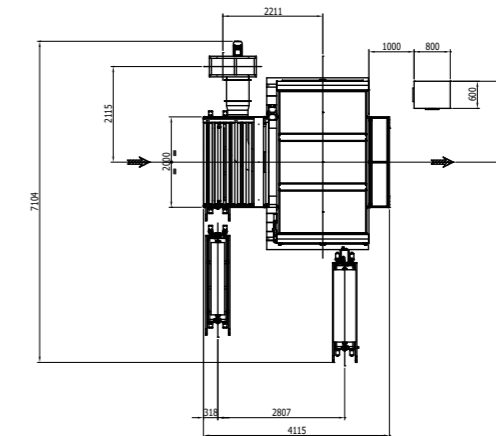
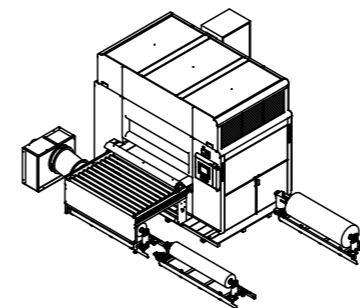

COMPACT 3 P

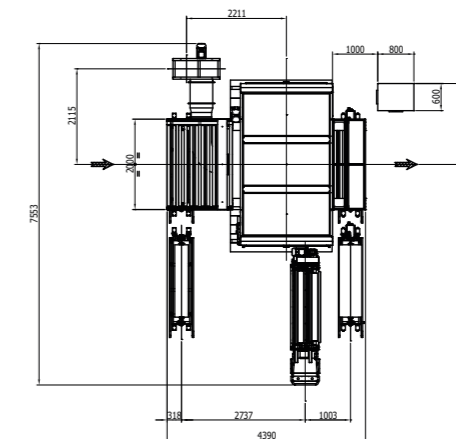
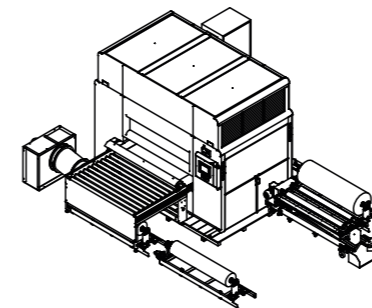

COMPACT 3 Hy

### COMPACT 3 R

Total installed power	kW 15,7
Machine length	mm 3385

### COMPACT 3 P

Total installed power	kW 15
Machine length	mm 4115

### COMPACT 3 Hy

Total installed power	kW 16,5
Machine length	mm 4390

### COMPACT 3 R - COMPACT 3 P - COMPACT 3 Hy

Working width	mm 1300
Working height	mm 900 (± 20)
Feed speed	m/min 2 ÷ 6
Reciprocator motor power	kW 4,4
Air volume	m <sup>3</sup> /h 8000
Cabin height	mm 2785
Cabin length	mm 2000
Cabin width	mm 3600

The technical data can vary according to the requested machine composition. In this catalogue, machines are shown with options. The company reserves the right to modify technical specifications without prior notice; the modifications do not influence the safety foreseen by the CE Norms.



# YOUR ART OF FINISHING

## Finishing lines signed off by Superfici add the most value to your product

Each Superfici finishing line is made with the most advanced technology and maximum versatility. Each solution is created from innovation and experience to add value to every detail and on any material. Many top brands in the world, which make quality their strong point, have chosen to rely on Superfici.



# THE STRONGEST WOOD TECHNOLOGIES ARE IN OUR DNA

## SCM. A HERITAGE OF SKILLS IN A UNIQUE BRAND

Over 65 years of success gives SCM the centre stage in woodworking technology. This heritage results from bringing together the best know-how in machining and systems for wood-based manufacturing. SCM is present all over the world, brought to you by the widest distribution network in the industry.

- 65 years history
- 3 main production sites in Italy
- 300.000 square metres of production space
- 17.000 machines manufactured per year
- 90% export
- 20 foreign branches
- 350 agents and dealers
- 500 support technicians
- 500 registered patents

In SCM's DNA also strength and solidity of a great Group. The SCM Group is a world leader, manufacturing industrial equipment and components for machining the widest range of materials.

## SCM GROUP, A HIGHLY SKILLED TEAM EXPERT IN INDUSTRIAL MACHINES AND COMPONENTS

### INDUSTRIAL MACHINERY

Stand-alone machines, integrated systems and services dedicated to processing a wide range of materials.



WOODWORKING TECHNOLOGIES



TECHNOLOGIES FOR PROCESSING COMPOSITE MATERIALS, ALUMINIUM, PLASTIC, GLASS, STONE, METAL

### INDUSTRIAL COMPONENTS

Technological components for the Group's machines and systems, for those of third-parties and the machinery industry.



SPINDLES AND TECHNOLOGICAL COMPONENTS



ELECTRIC PANELS



METALWORK



CAST IRON