

balestrini power

numerical control machining centre



INCREASE YOUR POTENTIAL



ALL MACHINING OPERATIONS



balestrini power mono



balestrini power 200



balestrini power 300



balestrini power 400



balestrini power 500



balestrini turbo power

WITH QUALITY
YOU HAVE ALWAYS WANTED

RAPIDITY



With the **5-axis revolver machining head units** all necessary tools are always ready-to-use. This guarantees unparalleled machining speed. As an alternative, **the machining head unit with single electrospindle PX5** is used for complex operations with heavy duty stock removal.

PRODUCTIVITY



In the **balestrini turbo power** version, cycle time is reduced and produced quantities are doubled thanks to the two 5-axis machining head units, working at the same time on the same worktable or on different tables, as two separate machines.

FLEXIBILITY



Balestrini power can be equipped with a **bars or multifunction worktable**.

The **bars worktable** has been designed to have maximum modularity according to the production needs.

It is possible to fix the **Combi, Jig free and CSR work piece locking devices**, that adapt perfectly to process pieces of any shape.

The SCM **multifunction aluminium worktable** guarantees perfect lasting planarity. The directly integrated vacuum system and special T-grooves allow optimal work piece clamping.

SAFETY



The **new CE protection enclosure** with horizontal sliding doors combines safety and optimal ergonomics during all work phases.

For the customer who wants to have a machine with reduced overall dimensions and, at the same time, be in complete safety, **CE protection enclosure with vertical sliding doors** is also available.

CLEANLINESS



The different solutions that can be equipped on the machine allow to keep clean the work environment and greatly reduce maintenance operations.

INNOVATION



Machine control is easy, effective and of immediate use through the touch screen of the **eye-M PRO** console and the new **Maestro active Human-Machine Interface**.

The new **Smart Pro CAD/CAM software** allows to generate work pieces and machining operations, optimize tool paths automatically and simulate in a single work environment, reducing greatly programming time.

The perfectly integrated new **Maestro connect IoT platform** visualizes, analyzes and monitors all data coming from the machine, essential to increase productivity, reduce operative, energy and maintenance costs.

27

Applications

28

Technical data

OVERVIEW OF TECHNICAL FEATURES

TECHNOLOGICAL ADVANTAGES

power



Linear or circular tool store anchored to the upright of the gantry.



N°2 worktables for machining in pendulum cycle.



Multifunction worktable suitable for any need of work piece referencing and locking.



Bars worktable configurable with Combi, Jig free and CSR work piece locking devices.



Bi-directional single-electrospindle or 5-axis revolver machining head unit with automatic tool change and liquid cooling.

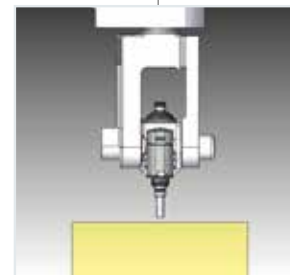

High vertical axis stroke which allows to process work pieces up to 920 mm in height.



eye-M PRO console installable on electrical cabinet or dedicated mobile support.

MACHINING HEAD UNITS



PX5 MACHINING HEAD UNIT

Guaranteed power and absolute rigidity for important material removal with PX5, the **bi-directional machining head unit** rotating around B and C axes, liquid cooled and with automatic tool change. Pneumatic brakes on B and C axes guarantee additional rigidity in 5-axis operations.



CS33 MACHINING HEAD UNIT

Fitting the machining centre with CS33 machining head unit, there are **3 independent electrospindles** always ready-to-use, one of which with tool change. Rotating around B and C axes, with a streamlined design, it allows to process complex-shaped work pieces. The liquid cooling guarantees a perfect efficiency for heat dissipation.

	PX5	CS33	CS44
Nominal power (S1) [n° x kW]	1 X 12 1 X 15	1 X 12 2 X 9.5 1 x 15 2 X 9.5	4 X 9.5
Max. Speed [rpm]	24000	24000	24000
Tool change	YES	YES	NO
Tool chuck	HSK 63 F	HSK 63 F + ER40	ER40
Liquid cooling	LIQUID	LIQUID	LIQUID

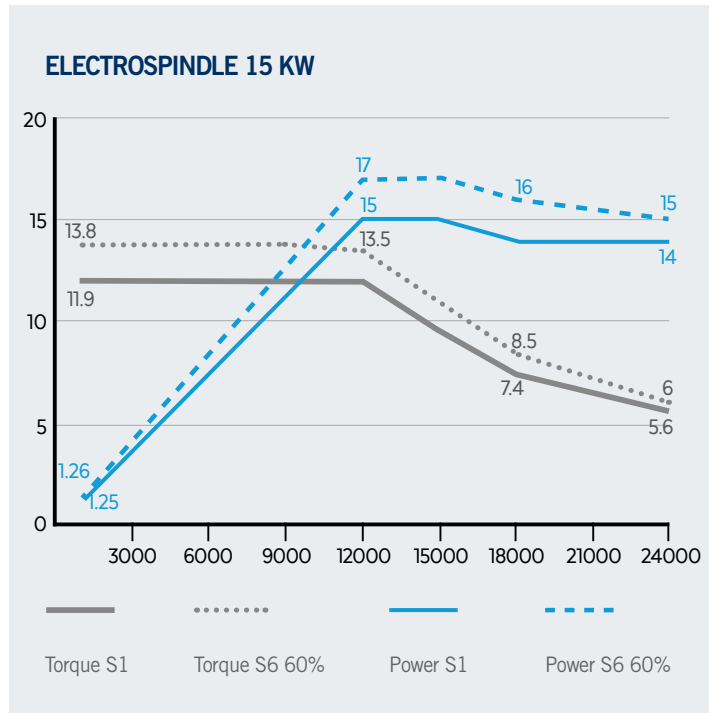



The machine is equipped with a Z-axis of 700 mm as standard. To process work pieces up to 920 mm in height, it is possible to request a **Z-axis of 1000 mm as option.**



CS33 and CS44 machining head units are equipped as standard **with liquid cooling and Z-axis pneumatic balancing with closed circuit**, fundamental requirements for important energy saving.

CS44 MACHINING HEAD UNIT

CS44 machining head unit is characterized by 4 **independent electrospindles**, liquid cooled and without tool change. Rotating around B and C axes, with a streamlined design it allows to process complex-shaped work pieces.

ELECTROSPINDLE 12 KW

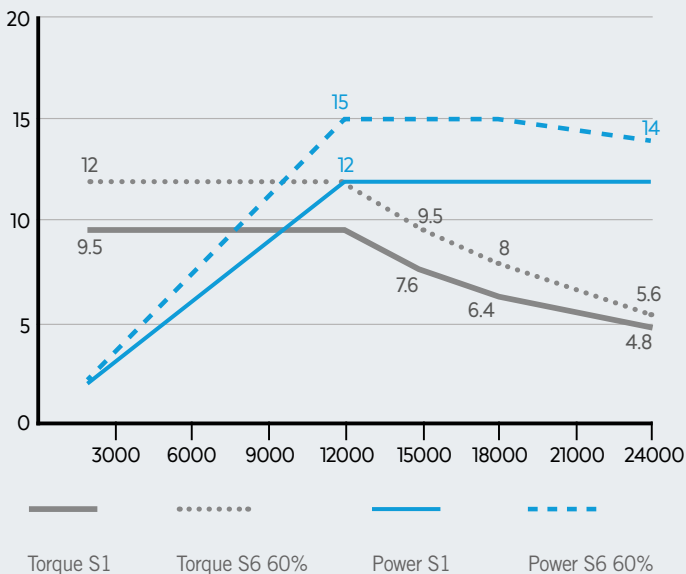

ELECTROSPINDLE 9,5 KW

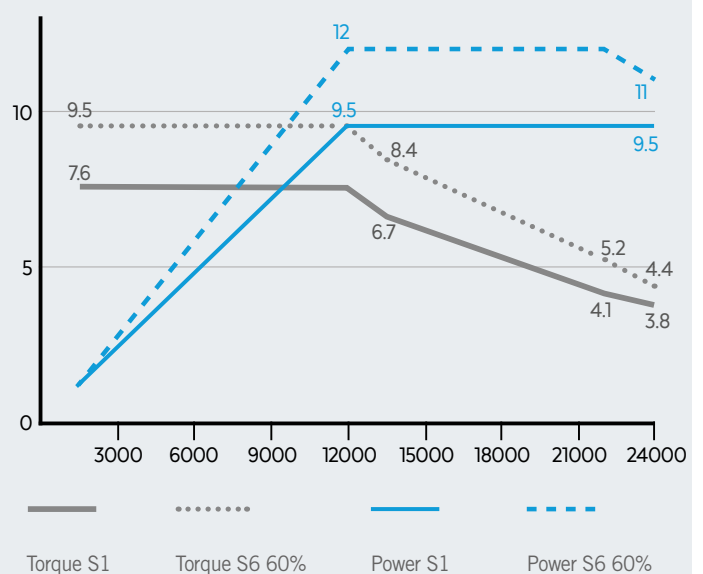

DOUBLE MACHINING HEAD UNIT

Increased productivity and flexibility thanks to the version with two 5-independent-axis machining head units.

The **balestrini turbo power** version is a real double machine, allowing to work in two different ways:



1. Two head units on the same worktable and the same work piece, halving cycle time.

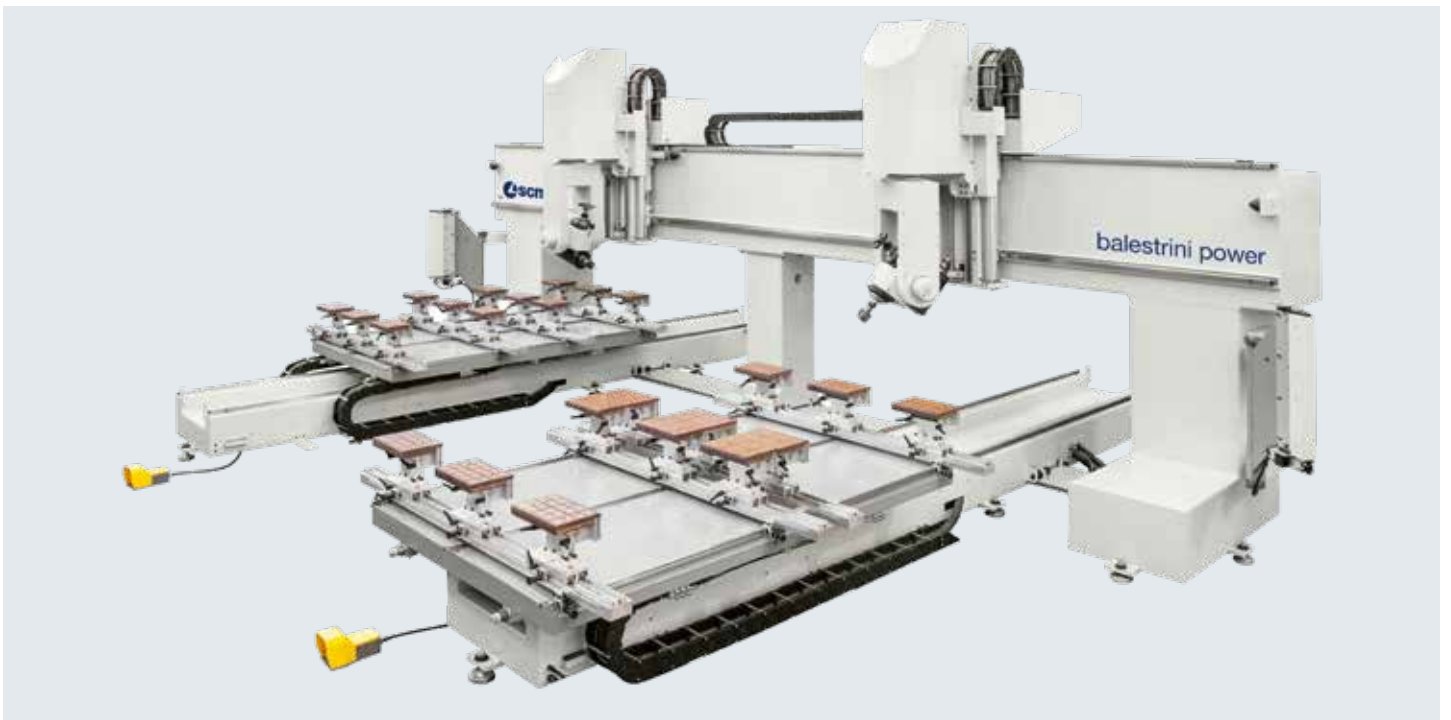

2. Two head units on different worktables and different work pieces, doubling the quantities to produce.

OPTIONS FOR MACHINING HEAD UNITS



DEVICE FOR TOOL MEASUREMENT AND AXES RE-SETTING

Mounted on a manually tilting column, it allows to:

- Measure tool diameter and length
- Re-set the axes.

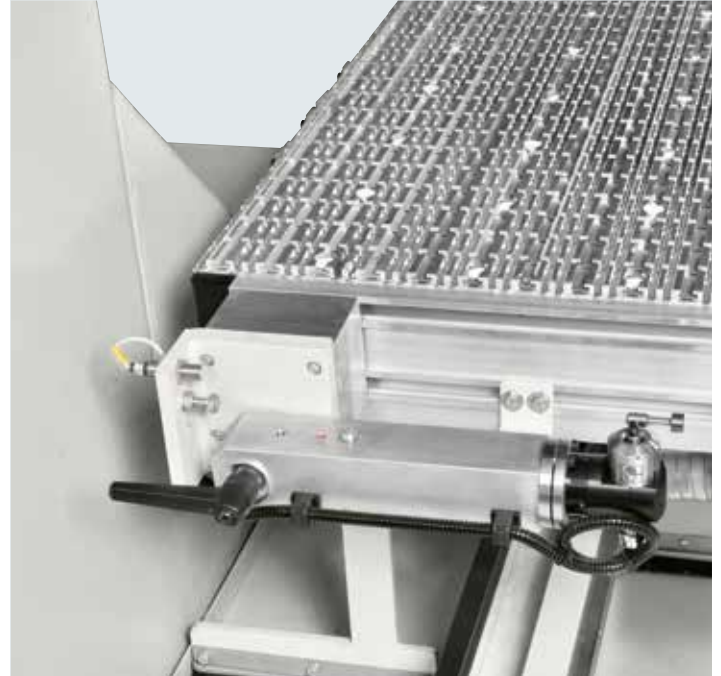

DRILLING UNIT ON CS33 AND CS44 MACHINING HEAD UNITS

To execute multiple holes in a single operation. Mounted on the head side and available with 5 or 7 vertical spindles.



DUST EXTRACTION HOOD ON PX5 MACHINING HEAD UNIT

By CNC controlled, it is the optimal solution to minimize dust produced during processing.

TOOL STORES



LINEAR TOOL STORE WITH 6 OR 8 POSITIONS

Linear vertical tool store anchored to the upright of the gantry. It is possible to equip the machine with one additional tool store, fitted on the opposite upright of the gantry.



CIRCULAR TOOL STORE WITH 16 OR 20 POSITIONS

Circular tool store anchored to the upright of the gantry. It is possible to equip the machine with one additional tool store, fitted on the opposite upright of the gantry.

	LINEAR		CIRCULAR	
	PX5 - CS33		PX5	
For machining head units			PX5	
N°positions	6	8	16	20
Centre distance between positions (mm)	115	82	138	108
Diameter without limitations max. (mm)	200	200	110	110
Diameter with sawblade max. (mm)	400	400	300	300
Tool length (tool holder included) max. (mm)	180	180	130	250
Single tool weight max. (Kg)	6	6	6	6
Loadable weight on tool store max. (Kg)	20	20	60	60

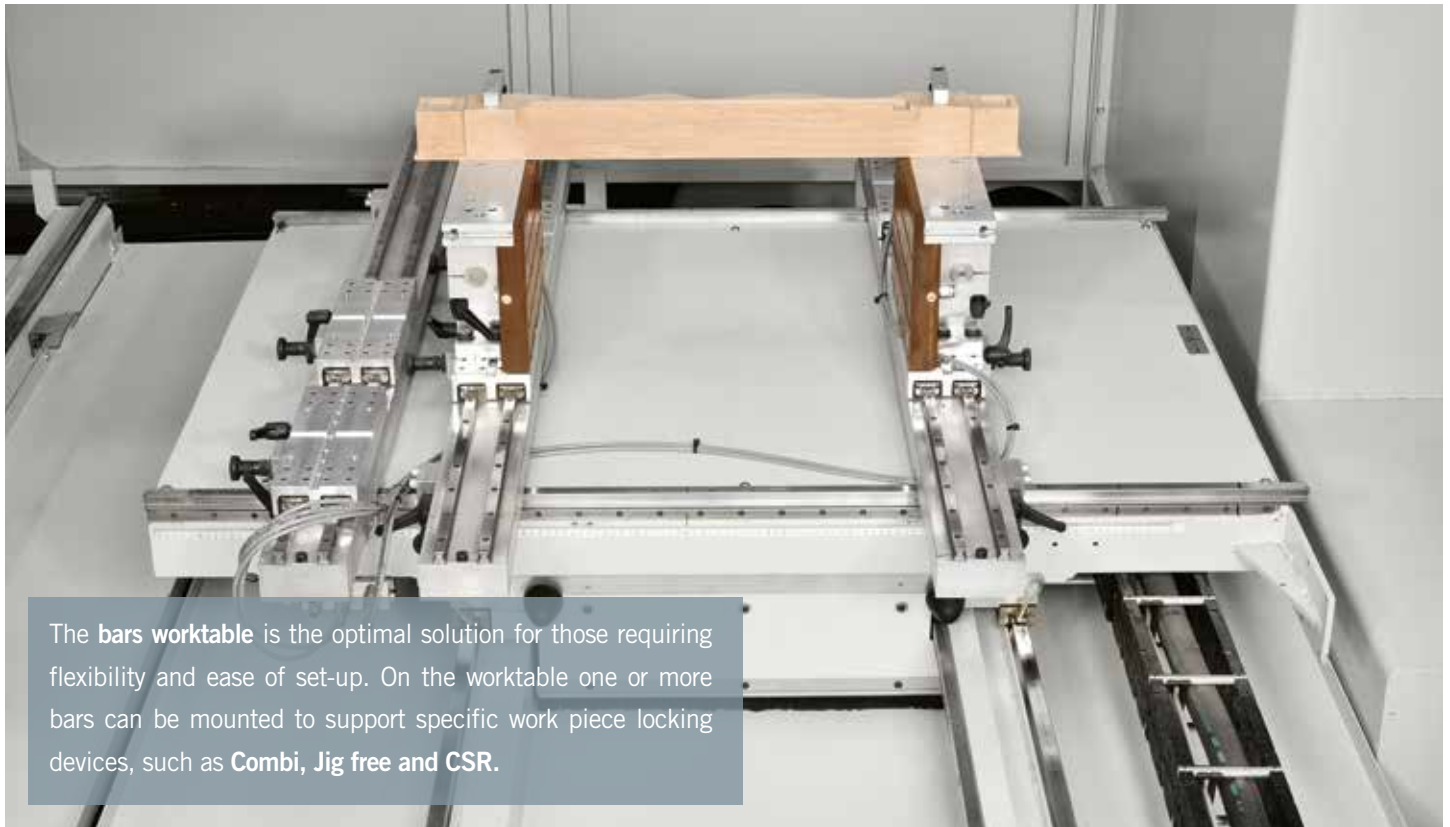

UNIVERSAL CARRIAGE

Each work piece locking device is blocked on the bar by a universal carriage, which can be moved along the bar itself. Millimeter lines and reference pins make manual set-up very precise.



RETRACTABLE REFERENCE STOP

Positioned on the crossbar end or on the worktable side, it guarantees a correct work piece reference.

BARS WORKTABLE

LOCKING DEVICES

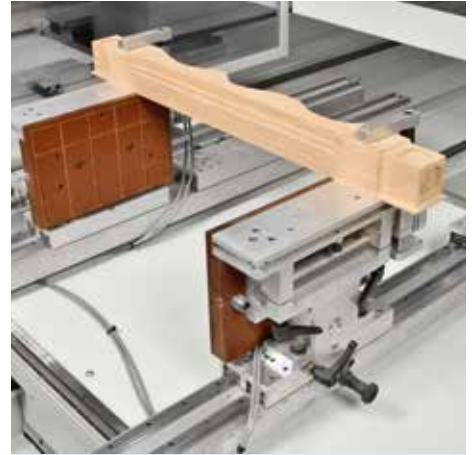

COMBI

The optimal device for locking jigs and large work pieces. Consisting of a vacuum table in squared bakelite and an aluminium table, arranged at right angles to each other. It is possible to equip the aluminium table with 1 or 2 clamps.



JIG FREE

For the simple and rapid locking of long work pieces, with relatively small cross-sections and requiring machining operations on 5 faces. The piece is correctly referenced thanks to a reference stop blocked on the Jig free side.



The Combi and Jig free work piece locking devices can be positioned on the worktable automatically by the machining head unit through a magnetic device fixed to its back side.

- The Jig free device can be positioned along X, Y and Z axes
- The Combi device can be positioned along X and Y axes



CSR

Economic solution in aluminium that allows to increase the height of the locked jigs, avoiding collisions between machining head unit and worktable.



VACUUM TABLE

Vacuum table in squared bakelite that allows to lock devices or work pieces.

MULTIFUNCTION WORKTABLE

The SCM aluminium multifunction worktable ensures maximum reliability. Characterized by a perfect lasting planarity, it does not deform despite changes in ambient factors such as temperature and humidity.



All over the worktable surface there are T-shaped grooves which allow rigid locking of any jigs and devices not provided by SCM. It is possible to configure the worktable with several types of suction cups, adding or removing them easily, depending on the type and geometry of the work pieces.

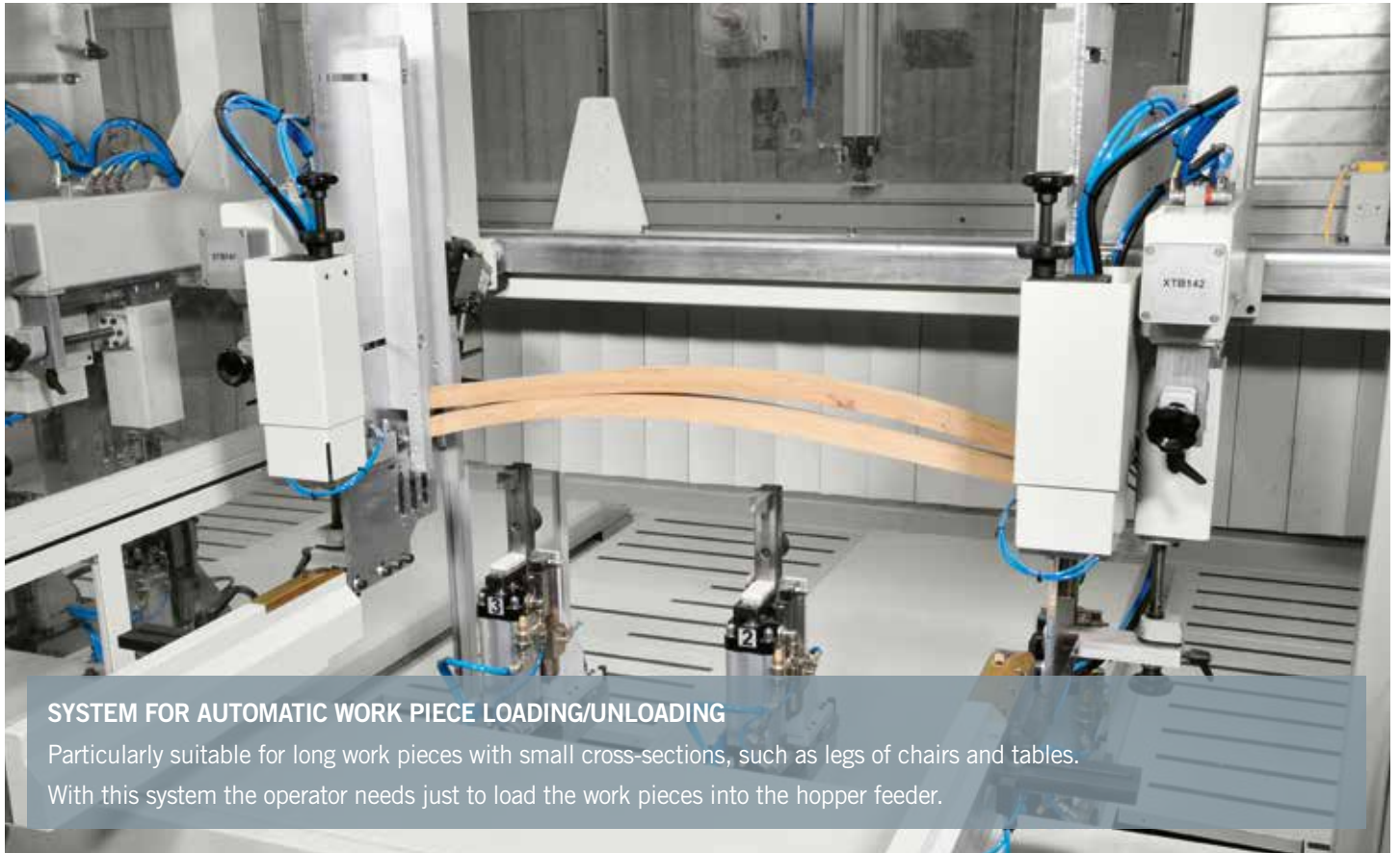

SYSTEM FOR AUTOMATIC WORK PIECE LOADING/UNLOADING

Particularly suitable for long work pieces with small cross-sections, such as legs of chairs and tables.
With this system the operator needs just to load the work pieces into the hopper feeder.



HEADSTOCK/TAILSTOCK "AXIS-LATHE" SYSTEM

Interpolated axis for processing long work pieces with cylindrical symmetry. It is available in two versions for processing work pieces of length up to 1050 mm and 1300 mm.

SAFETY SYSTEMS

Two types of protection enclosures keep the operator away from accidental ejection of work pieces and at the same time guarantee complete ergonomics in the manual or automatic loading/unloading process.



CE PROTECTION ENCLOSURE WITH HORIZONTAL SLIDING DOORS

It guarantees total accessibility to the loading/unloading area.



CE PROTECTION ENCLOSURE WITH VERTICAL SLIDING DOORS

It allows to combine safety and compactness, thanks to the reduced machine overall dimensions.

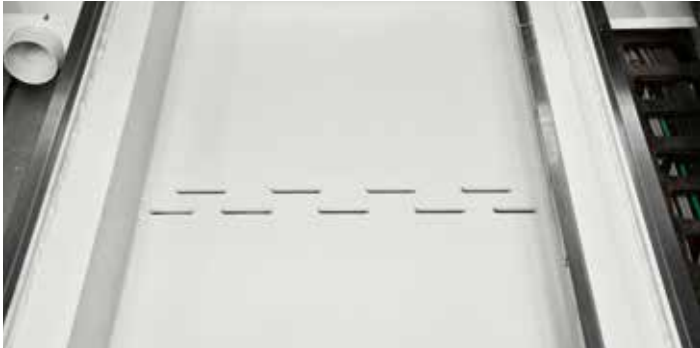

EXTRACTION SLOTS ON THE MACHINE BED

With direct connection to the extraction system to prevent shavings accumulation.



COLLECTION TANKS FOR SHAVINGS AND WASTE

Positioned at the machine bed side, they allow to convey shavings and waste towards the machine front and rear sides.



CONVEYOR BELT FOR SHAVINGS AND WASTE

Positioned in the rear area of the machine, it allows to convey shavings and waste towards an extraction system externally to the machine.



FULL ENCLOSURE

It provides complete machine enclosure and guarantees a dust-free environment, thanks to the connection of the extraction system to three outlets.



EYE-M PRO CONSOLE

balestrini power
numerical control machining centre



Operator panel with linear design, simple and elegant, emphasizing the "full screen" effect.
The integrated LED bar allows the operator to know at any time the status of the machine.



2 possible installations: in the electrical cabinet or on independent mobile support.

M Maestro Digital Systems

SMART SOFTWARE AND DIGITAL SERVICES TO ENHANCE PRODUCTIVITY OF WOODWORKING AND FURNITURE INDUSTRIES.

design > programming and data generation

Maestro office

Office

Factory

Maestro active

cutting > routing drilling

SOFTWARE

Simple, smart and open

Maestro software are tailored on the machine technology as well as on the entire process. All Maestro software share a common mission:

easy to use, so that any operator can easily and confidently learn and use the software

smart, with algorithms and computing modules aiming at the best possible result

open in order to integrate existing software, and provide customer the coverage of all his process.



SCM accompanies woodworking companies throughout their whole process combining machines with matching software solutions and digital services, with a constant strive to enhance company productivity.

The software solutions powered by SCM are developed to optimize machine usage as well as the entire process, providing integration with the different software existing in the company.

DIGITAL SERVICES

Transforming the way it delivers services to its customers through digital technologies and particularly, the IoT platform that collects and analyses data coming from the machine, **SCM created a world of services enabled by Maestro connect.**

Meaning that connecting an SCM machine through Maestro connect will let customer subscribe a program of fast-evolving services and access a wide range of benefits that even go beyond the machine experience and will support and assist you through the whole life-cycle of your machine.

Maestro connect IoT Platform

1
Machine monitoring,
KPIs, early warning

2
Maintenance
equipment

3
Predictive
maintenance

4
Report and historical
data export to MES

5
Warranty
extension

6
Augmented
remote support

7
Smart learning,
SELF-HEALING, video
tutorials





Smart Pro



SMART PRO is an extremely advanced CAD/CAM software. It enables to create and manage routing, drilling, cutting, etc. operations with simplicity and reliability. Smart Pro is available in two versions:

- **Basic version:** 3 axis CAD/CAM software, with the possibility of importing 5-axis paths from external software.
- **Advanced version:** 5 axis CAD/CAM software.

SOFTWARE

Office

FUNCTIONS

Thanks to the 3D design of the machine complete of its work piece locking devices, the software allows to perform:

SIMULATION

The software allows to simulate a work cycle preview, visualizing any modification and optimization introduced with important time-saving in machine setting and sample piece manufacturing.

COLLISION CONTROL

The software highlights any interference between tools and work piece or machine parts.

OPTIMIZATION OF FREE PATHS

The software allows to optimize automatically the movements of the tools in the transition from one process to the next one.

MACHINING MACRO

The software has MACROs that simplify and speed up the programming of repetitive work operations.

INTEGRATION OF 5-AXIS TOOL PATHS

The software allows to import and integrate tool paths programmed on other CAD/CAM systems.

CAD PERFORMANCES

The software allows to draw free paths and manage several CAD formats, so as to be able to easily import the drawings of the pieces to be placed and processed on the machine.



Maestro active cnc

Maestro active is the new operator interface software which has been unified across all SCM technologies. A single operator can easily and confidently run multiple machines due to controller and interface consistency: regardless the machine, Maestro active maintains the same look&feel, with many identical icons and navigation buttons, thus ensuring the same approach to interaction.

EASE OF USE

The new interface has been specifically designed and optimized for immediate use via touch screen. Graphics have been redesigned for simple and comfortable navigation, with tablet-like icons on touch screen controller.

“ZERO” ERRORS

Improved productivity thanks to integrated help and recovery procedures that reduce the possibility of error from the operator’s side.

SOFTWARE

Factory

Maestro active cnc

A REVOLUTIONARY APPROACH TO INTERACT WITH YOUR SCM MACHINE

FULL MACHINE AWARENESS AND KNOWLEDGE MANAGEMENT SYSTEM

Maestro active allows to record the times related to setup, maintenance, training and other events, tracing all the activities in a database. The operator’s know-how is also stored and made available to other people inside the organization thanks to the possibility to comment and document all events.

ORGANIZE YOUR PRODUCTION

Maestro active allows to create different users with different roles and authorizations (e.g.: operator, maintainer, administrator, ...). Any user can only execute the functions whose permissions have been assigned to him. It is also possible to define the work shifts on the machine and then detect activities, productivity and events that occurred in each shift.

TOTAL QUALITY OF THE FINISHED PRODUCT

With Maestro active the quality of the finished piece is no longer put at risk by worn tools. The new Maestro Active Tool Life Determination system sends notification messages as the tool reaches its end of life and recommends its replacement at the most appropriate time.

TOOLS? NO PROBLEM!

Maestro active guides the operator during the tool change phase.

A WORLD OF SERVICES FOR GREATER EFFICIENCY

Maestro connect

CONNECT YOUR MACHINE AND GAIN ACCESS TO A WORLD OF SERVICES

Connecting your machine through Maestro connect will let you subscribe a program of fast-evolving services. You will access a wide range of benefits that even go beyond the machine experience and will support and assist you through the whole life-cycle of your machine.

FASTER SERVICE INTERVENTION AND PROBLEM RESOLUTION

Maestro connect provides real time data and Health Records of the Machine also to SCM Service drastically reducing its troubleshooting time.

WORKING ALWAYS IN PERFECT CONDITIONS

Maestro Connect can provide a full kit of sophisticated sensor devices to detect and warn the operator in case of alarming conditions of the machine.

DIGITAL SERVICES

SMART MAINTENANCE: DOWN TIME REDUCTION

Maestro connect reduces maintenance downtime thanks to:

- automatic maintenance notifications and scheduling, to prevent failures and work in the best conditions of use
- direct connection to SCM Service thanks to an automatic ticket opening function

SMART MACHINE: ANYTIME, ANYWHERE AWARENESS

Connecting your SCM machine also means having your machine always at hand. Immediate instant notifications in case of alarms or downtimes allow customers to immediately take an action thus optimizing his productivity.

SMART MANAGEMENT: PRODUCTION PERFORMANCE OPTIMIZATION

Reports and KPIs allow further analysis thus increasing Customer Knowledge about his performance and results.

SMART LEARNING: EXECUTE WORK AND RECEIVE PROBLEM SOLVING SUPPORT

Maestro connect provides an intuitive Problem Solving Management System to help the operator to self solve any issue.

SMART WARRANTY: YOUR MACHINE ALWAYS IN PERFECT CONDITIONS

Together with scheduled maintenance contracts, you can take care of your asset by doubling the warranty from 1 year to 2 years* for complete peace of mind!

** please read the complete contract to understand terms and conditions.*

APPLICATIONS

balestrini power
numerical control machining centre

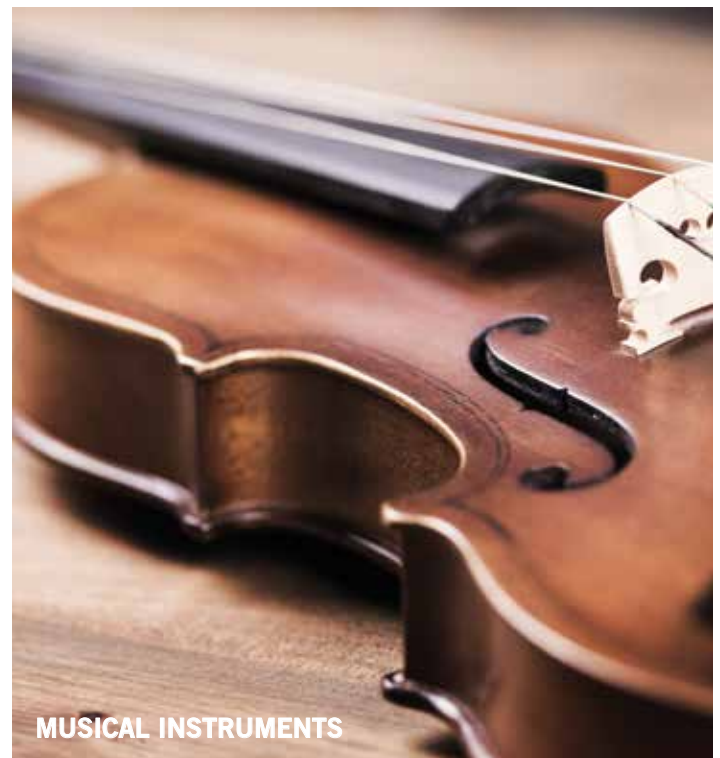

TECHNICAL DATA

WORKTABLE DIMENSIONS

MODEL	VERSION	Y (mm)	X* (mm)	L (mm)	Turbo power version
balestrini power mono	150	1500	2000	2200	NO
	250	2500			
balestrini power 200	75	750	1000	3200	NO
	150	1500			
balestrini power 300	250	2500	1500	4200	NO
	75	750			
balestrini power 400	150	1500	2000	5200	YES
	250	2500			
balestrini power 500	150	1500	2500	6200	YES
	250	2500			

(*) Nominal dimensions

L = Distance between the uprights of the gantry

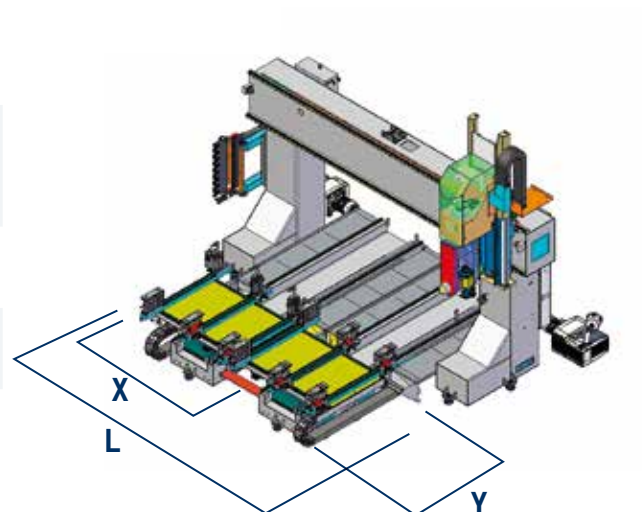

MACHINING VOLUME

MODEL	VERSION	E (mm)	F (mm)	G (mm)	H (mm)
balestrini power mono	150	2000	2000	1500	620/920
	250			2500	
balestrini power 200	75	1000	2000	750	620/920
	150			1500	
balestrini power 300	250	1500	3000	1500	620/920
	75			750	
balestrini power 400	150	2000	4000	1500	620/920
	250			2500	
balestrini power 500	150	2500	5000	1500	620/920
	250			2500	

H = distance from worktable to electrospindle (tool holder included)
for Z-axis stroke = 700 mm and 1000 mm

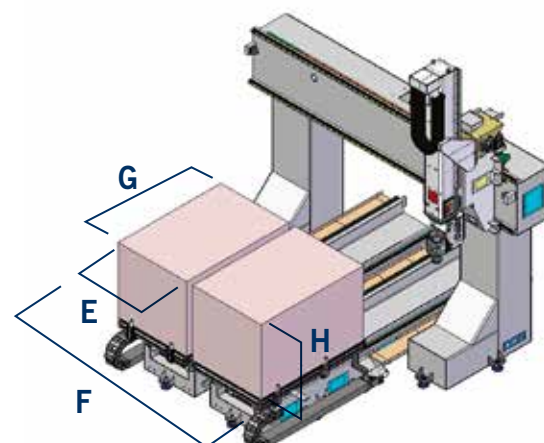

MACHINE OVERALL DIMENSIONS

MODEL	VERSION	Protection enclosure with horizontal sliding doors				Protection enclosure with vertical sliding doors			
		A	B	C	D	A	B	C	D
balestrini power mono	150	4050	5350	5160	2200	NOT AVAILABLE			
	250			7260		NOT AVAILABLE			
balestrini power 200	75	4050	5350	3800	2200	4050	4900	3150	2200
	150			5400				4750	
	250			7500				6800	
balestrini power 300	75	4050	6350	3800	2200	4050	5900	3150	2200
	150			5400				4750	
	250			7500				6800	
balestrini power 400	150	4050	7350	5400	2200	NOT AVAILABLE			
	250			7500		NOT AVAILABLE			
balestrini power 500	150	4050	8350	5400	2200	NOT AVAILABLE			
	250			7500		NOT AVAILABLE			

A = dimension for Z-axis stroke = 1000 mm

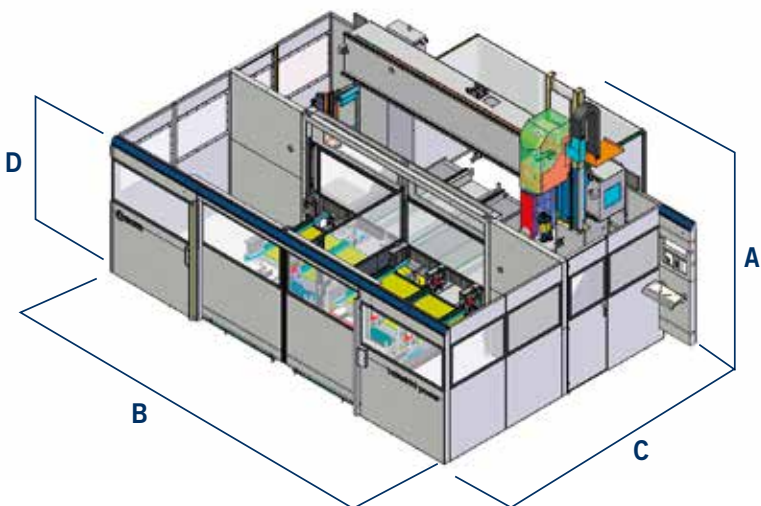

Protection enclosure with horizontal sliding doors

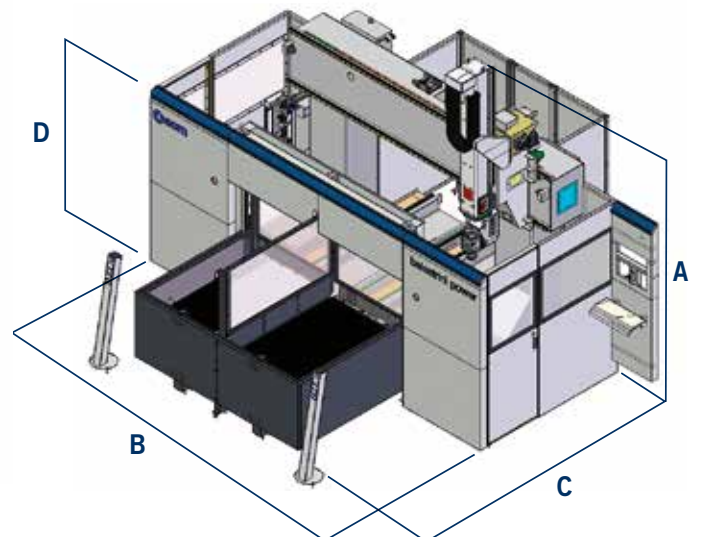

Protection enclosure with vertical sliding doors

TECHNICAL DATA

LINEAR AXES

X-axis stroke	mm	3000 - 4000 - 5000 - 6000
Y-axis stroke	mm	1800 - 2550 - 3550
Z-axis stroke	mm	700 - 1000
X - Y - Z axes speed	m/min	90 - 90 - 60

WORKTABLES

Type	Bars worktable - Multifunction worktable	
------	--	--

MACHINING HEAD UNITS

Type	PX5 - CS33 - CS44	
Max. rotation	rpm	24000

ROTATING AXES

B Rotation	°	+/- 120 (PX5) – 360 in continuous (CS33 and CS44)
C Rotation	°	+/- 270 (PX5) – +/- 370 (CS33 and CS44)

TOOL STORES

Linear	N° positions	6 - 8
Circular	N° positions	16 - 20

INSTALLATION

Nominal compressed air pressure	bar	6
Compressed air consumption	NI/min	250

**COMPANY WITH
QUALITY SYSTEM
CERTIFIED BY DNV GL
= ISO 9001 =**

The technical data can vary according to the requested machine composition. In this catalogue, machines are shown with options. The company reserves the right to modify technical specifications without prior notice; the modifications do not influence the safety prescribed by CE Norms.

Maximum recorded noise levels based on functioning parameters established by ISO 3746/1995. Acoustic pressure while working 83 dbA (measured according to EN ISO 11202:1997, K variance = 4 dB).

Despite the existence of a correlation between "conventional" noise emission values mentioned above and average personal exposure of the operators during the 8 hours, these also depend on the specific functioning conditions, length of exposure, acoustics characteristics of the working environment and by the presence of additional sources of noise, that is the number of machines and adjacent processes.

THE STRONGEST WOOD TECHNOLOGIES ARE IN OUR DNA

SCM. A HERITAGE OF SKILLS IN A UNIQUE BRAND

Over 65 years of success gives SCM the centre stage in woodworking technology. This heritage results from bringing together the best know-how in machining and systems for wood-based manufacturing. SCM is present all over the world, brought to you by the widest distribution network in the industry.

65 years history

3 main production sites in Italy

300.000 square metres of production space

20.000 machines manufactured per year

90% export

20 foreign branches

400 agents and dealers

500 support technicians

500 registered patents

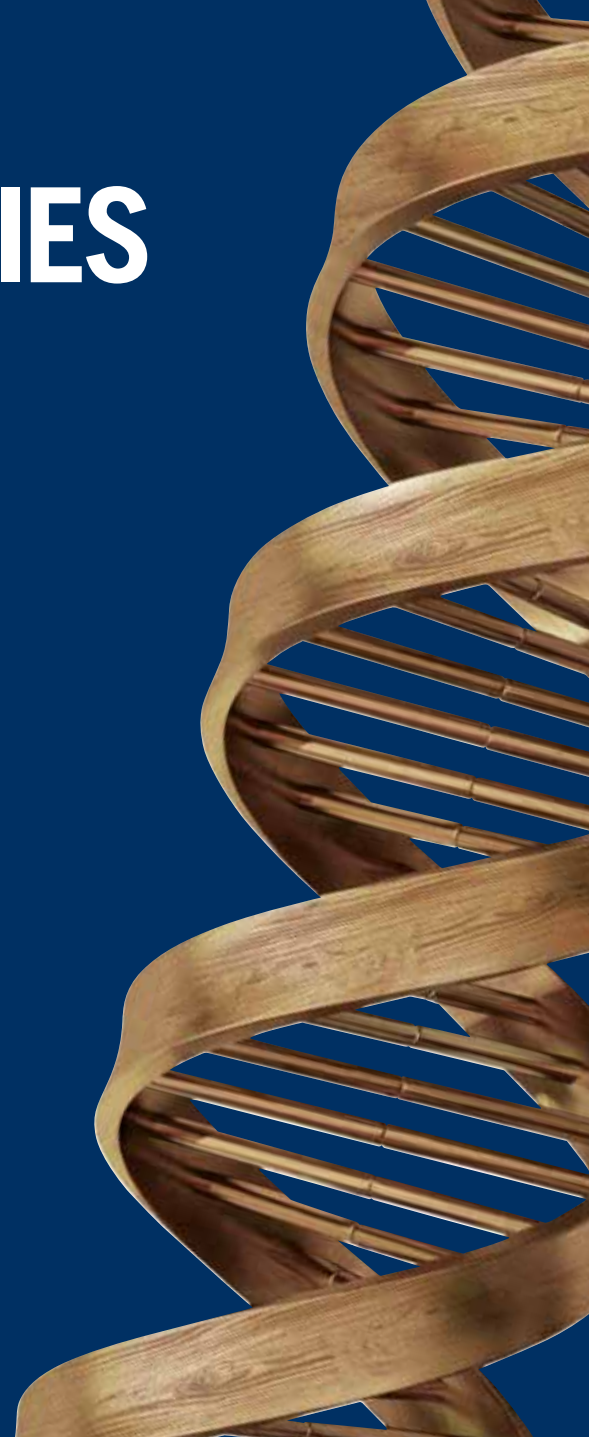

In SCM's DNA also strength and solidity of a great Group. The SCM Group is a world leader, manufacturing industrial equipment and components for machining the widest range of materials.

SCM GROUP, A HIGHLY SKILLED TEAM EXPERT IN INDUSTRIAL MACHINES AND COMPONENTS

INDUSTRIAL MACHINERY

Stand-alone machines, integrated systems and services dedicated to processing a wide range of materials.



WOODWORKING TECHNOLOGIES



TECHNOLOGIES FOR PROCESSING
COMPOSITE MATERIALS, ALUMINIUM,
PLASTIC, GLASS, STONE, METAL

INDUSTRIAL COMPONENTS

Technological components for the Group's machines and systems, for those of third-parties and the machinery industry.



SPINDLES AND
TECHNOLOGICAL
COMPONENTS



ELECTRIC PANELS



METALWORK



CAST IRON



is more



SCM GROUP SPA

via Casale 450 - 47826 Villa Verucchio, Rimini - Italy
tel. +39 0541 674111 - scm@scmgroup.com
www.scmwood.com



00L0529266D